

MAZ - MAN



TRUCK TRAILER 6x2

TRUCK TRAILER -
CHASSIS MAZ-MAN (6X2)
AND SEMI-TRAILER WITH TOTAL
CAPACITY UP TO 120 M³



Gross mass of truck trailer, kgup to 44 000
Equipped truck mass, kg8 800
EngineEuro-3 (Euro-2)
Engine power, kw (h.p.)301 (410)
Control fuel consumption at V=60 km/hr
and gross mass of truck trailer, l/100 km27.9

*Standard
of quality!*



▲ CHASSIS MAZ-MAN 630168 (6X2)

Chassis 6x2 is designed for mounting of platform, awning or rigid body, as well as various special equipment. It can be used as a single vehicle or as a part of truck trailer (with total capacity up to 120m³).



JSC "MAZ-MAN"
MANUFACTURING PLANT
HEAVY LOAD TRUCKS
OF WEST-EUROPEAN QUALITY

220021, Republic of Belarus, Minsk, Tsentralnaya str., 3A
Tel. (+375 17) 217-62-00; fax 217-62-01
Sales department: (+375 17) 217-62-10, 217-62-14, 217-62-15; fax 217-62-11
Service department: (+375 17) 217-62-46, 217-62-47, 217-62-19; fax 217-62-48
e-mail: sales@maz-man.com.by <http://www.maz-man.by>

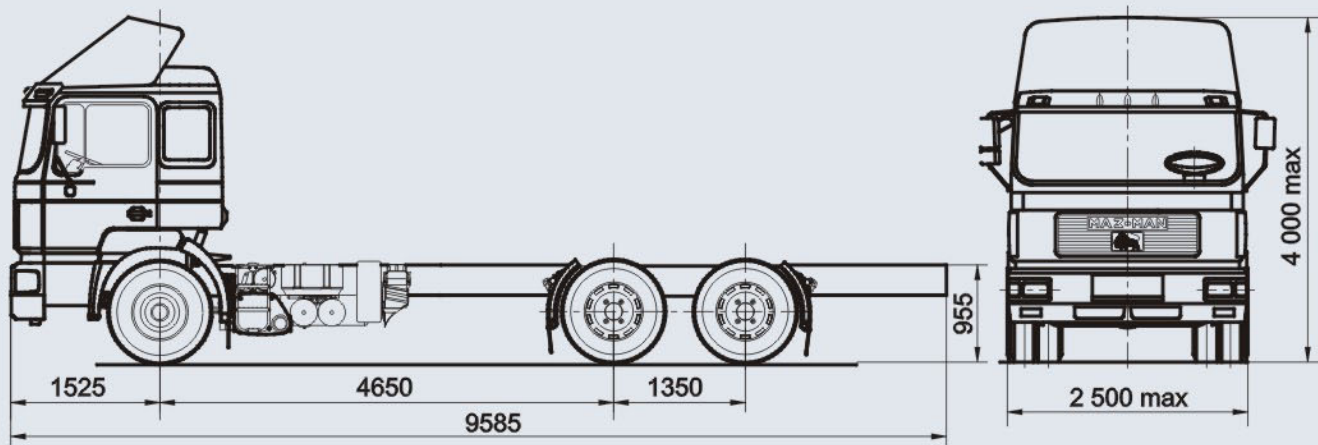

STANDARD MODIFICATION OF CHASSIS MAZ-MAN 630168 (6x2)

Technical parameters	<ul style="list-style-type: none"> Wheel base 4 650** mm x 1 350 mm + 1 525 mm front frame overhang Equipped truck mass - 8 800 kg Permissible gross mass - (26 500 kg) 24 900* kg Front axle load - 6 700* kg (7 500 kg) Rear axle load - 11 500 kg Additional (lifted) axle load - 6 700* kg (7 500 kg)
Engine	<ul style="list-style-type: none"> MAN D 2866 LF 25 (LF 31); EURO-3 (EURO-2) Engine power - 301 kw (410 h.p.); Electronic control of fuel feed (EDC)
Gearbox	ZF, synchronized, type 16 S 181, 16+2
Clutch	VALEO (F&S), one disk, dry clutch, hydraulic drive, pneumatic support
Drive	<ul style="list-style-type: none"> Anti-lock brake system (ABS) Anti-slipage system (ASR) Speed limiter (Tempomat)
Axles	<ul style="list-style-type: none"> Front axle - curved beam with needle bearing in swivel coupling Rear axle - drive axle with planetary wheel gearing, differential's blocking and gear ratio $i=3.55^*$ (3.68) Additional (lifted) axle with automatic lowering at max load of rear axle and short-term automatic lifting at starting on slippery roads
Suspension	<ul style="list-style-type: none"> Front - three-leaf springs with hydraulic shock-absorbers of the dual-side action and stabilizers Rear - two air springs pneumatic suspension for drive and lifted axle ECAS system automatic adjustment of rear suspension
Cabin external equipment	<ul style="list-style-type: none"> *MAN "F-2000" of high roominess, width 2.440 mm, with two sleeping bunks Cathodic dip paint-work and cavity sealing *Four-point suspension on helical springs with cross stabilizer *Spoiler of the same color as cabin Sun visor over the windscreen Hydraulic cabin tilt Safety triplex windscreen laminated glass Heated, electrically regulated mirrors: back view (2), panoramic view and curb view Reinforced steel front bumper Tool boxes (40 l) on each side
Cabin internal equipment	<ul style="list-style-type: none"> *Two sleeping bunks Driver's seat pneumatic suspension "Isringhausen" Three-point safety belts for driver and passenger Driver's wheel with regulation of height and angle Pneumatic and electric horn Door niches, niches above windscreen and between the seats Tachograph electrical for two drivers "Kienzle" Electrical glass lifts *Outputs for radio connection 12 V, including antenna and loud-speaker *Independent air cabin heater "Eberspacher"
Brakes	<ul style="list-style-type: none"> Dual circuit pneumatic braking system with drum (disk) brakes Asbestos-free brake lining Brake system device "WABCO" Air dehumidifier for brakes with heating Pneumatic low noise exhaust valve brake
Electrical equipment	<ul style="list-style-type: none"> Alternator 28V/100A (2800 W) for Euro-3 engine or 28V/80A (2240 W) for Euro-2 engine *Battery VARTA 180 A.h Starter Bosch A001 450 321; 5.4 kw Twin halogen headlights *Two fog back-lights and two back lanterns *Additional halogen and fog lights Trailer headlights on sun visor
Fuel system	<ul style="list-style-type: none"> *Fuel tank 500 l (700 l) with screen filter Heated main fuel filter *Heated fuel filter water-separator "Separ-2000"
Wheels	<ul style="list-style-type: none"> *Tires 295/60R22.5 (315/80R22.5; 295/80R22.5) (tubeless) of West European origin *Disks 9.00"-22.5" - "Kronprinz", Germany or "Gianetti", Italy
Accessories	<ul style="list-style-type: none"> Standard tool kit (fire-extinguisher, first-aid kit, anti-rolling shoe, etc.) *Additional tool kit on frame
Certificates	<ul style="list-style-type: none"> Certificate "3" - "Euro-3 sicheres/Euro-3 safe truck" Certificate "S" - "Supergrunes und sicheres/Especially green and safe truck" (Euro-2) Certificate "L" - "Larmarme Kraftfahrzeuge/Reduced noise" * - parameters of basic modification ** - parameters variable according to modification and purpose