

MAZ - MAN



DUMP TRUCK

8x4

CONSTRUCTIONAL ADVANTAGES OF THE VEHICLE



- HIGH MOBILITY
- DRAFT DYNAMICS



- HIGH PAYLOAD CAPACITY
- LIFTED, SELF-ADJUSTED REAR AXLE



- FUEL AND TIRE ECONOMY AT DEADHEADING
- POSSIBILITY OF FORCED INCREASE OF DRAFT DYNAMICS
- INCREASED SMOOTHNESS OF MOTION IN EQUIPPED CONDITION
- POSSIBILITY OF FORCED ADJUSTMENT OF FRONT AXLE LOAD
- HIGH CROSS STABILITY AT UNLOADING
- SAVING IN MAINTENANCE

Gross mass of truck, kg..... up to 44 000
Equipped truck mass, kg14 000
Payload capacity, kgup to 30 000
Platform capacity, m³16,5÷20
EngineEuro-2 (Euro-3)
Engine power, kw (hp) 301 (410), 338 (460)

Standard of quality!



JSC "MAZ-MAN"
MANUFACTURING PLANT
HEAVY LOAD TRUCKS
OF WEST-EUROPEAN QUALITY

220021, Republic of Belarus, Minsk, Tsentralnaya str., 3A
Tel. (+375 17) 217-62-00; fax 217-62-01
Sales department: (+375 17) 217-62-10, 217-62-14, 217-62-15; fax 217-62-11
Service department: (+375 17) 217-62-46, 217-62-47, 217-62-19; fax 217-62-48
e-mail: sales@maz-man.com <http://www.maz-man.by>

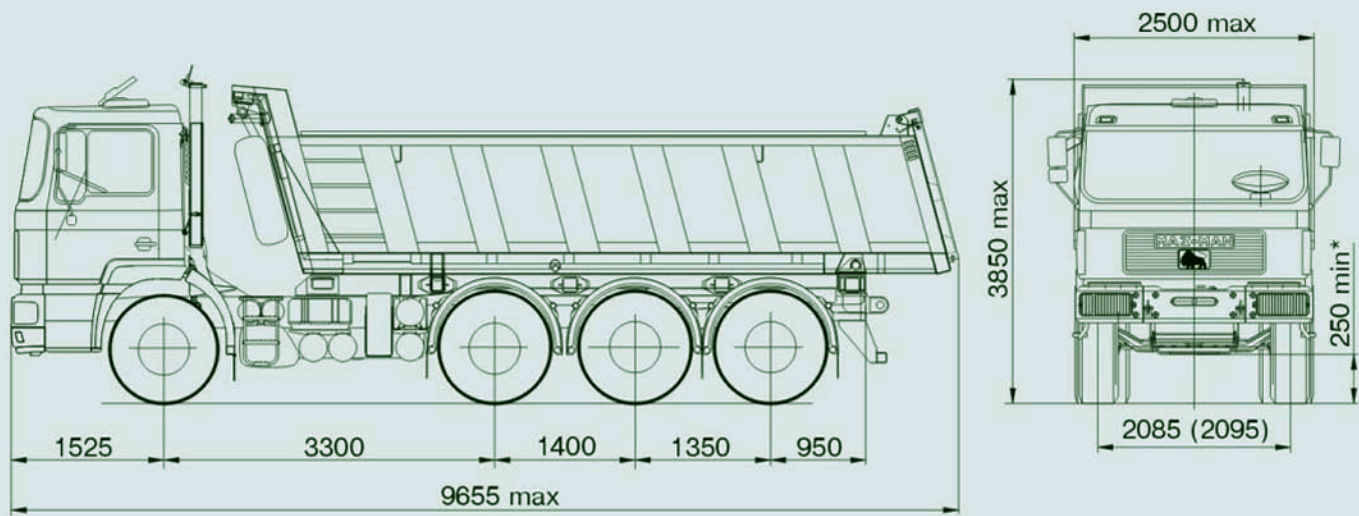

STANDARD MODIFICATION OF DUMP TRUCK MAZ-MAN 750268 (8x4)

Technical parameters

Gross mass of dump truck 42 500 (44 000) kg
 Equipped truck mass 14 500 kg
 Payload capacity up to 30 000 kg
 Platform capacity 16,5; 20 m³

Engine

- * MAN D 2866 LF 25 (LF 31); EURO-3; (EURO-2)
- Engine power - 301 kw (410 hp)
- Electronic control of fuel feed (EDC)
- * Air intake behind the cabin with dry filter element
- * Exhaust silencer on one side with exhaust to the left or to the top
- * Anti-slipage system (ASR)
- Speed limiter (Tempomat)

Gearbox

- * ZF, type 16 S 181, 16+2

Clutch

VALEO, one disk, dry clutch, hydraulic drive, pneumatic support

Drive

Reinforced cardan shaft

Front axle

Front axle curved beam with needle bearing in swivel coupling

Drive bridges

With planetary wheel gearing
 Interwheel and interbridge differential's blocking

Rear axle

Lifted, self-adjusted, with forced system of turn blocking

Suspension

Front three-leaf springs with hydraulic shock-absorbers of the dual-side action and stabilizers of cross stability with payload capacity up to 9 t
 Double axle suspension spring balancing with stabilizer of cross stability
 Rear axle suspension pneumatic

Cabin external equipment

- * MAN "F-2000" small cabin, without sleeping bunks
- Cathodic dip paint-work and cavity sealing
- * Four-point suspension on helical springs with cross stabilizer
- * Sun visor over the windscreen
- * Reinforced steel front bumper with radiator protection and headlights grid
- Heated, electrically regulated mirrors: back view (2), panoramic view and curb view

Cabin internal equipment

- * Without sleeping bunks
- Round shutter and sun shutters in front of the windscreen
- Comfortable driver's seat with pneumatic suspension "Isringhausen"
- Three-point safety belts for driver and passenger
- Driver's wheel with regulation of height and angle
- Tachograph electrical for one driver "Kienzle"
- * Right door electrical glass lift
- * Pneumatic and electric horn
- Door niches, niches above windscreen and between the seats
- * Outputs for radio connection 12 V, including antenna and loud-speaker
- * 12V, 180 W outlet in cabin
- * Independent air cabin heater "Eberspacher"

Braking system

- * Anti-lock brake system (ABS)
- * Dual circuit pneumatic braking system with drum brakes
- * Brake system devices "WABCO"
- Pneumatic low-noise Exhaust Valve Brake
- Heated air dehumidifier for brakes
- Asbestos-free brake lining

Electrical equipment

- Alternator 28 V/80A (2240 W)
- * Battery VARTA 2 x 180 A h
- * Two fog back-lights and two back lanterns

Fuel system

- * Fuel tank 500 l with screen filter
- Heated main fuel filter
- * Heated fuel filter water-separator "Separ-2000"

Wheels

- * Tires 12/OOR20 - 8 pcs, 385/65R22,5 5 pcs
- * Disks 8,5-20, 9-22,5, 11,75-22,5

Accessories

Standard tool kit (fire-extinguisher, first-aid kit, anti-rolling shoe, etc.)
 Additional tool kit on frame

Certificates

- * Certificate "3" "Euro-3 sicheres/Euro-3 safe truck"
- * Certificate "S" "Supergrünes und sicheres/Especialy green and safe truck" (Euro-2)
- * - options are available