

MAZ - MAN



TRUCK TRACTOR 6x4



▲ **FOR NORTHERN CONDITIONS
(NORTHERN PACKAGE) (up to -60°C)**



▲ **FOR TRANSPORTATION OF
DANGEROUS CARGOES (ADR)**



▲ **FOR INTERNATIONAL
TRANSPORTATION**



▲ **FOR TROPICAL CONDITIONS
(TROPICAL PACKAGE)**

Gross mass of truck, kgup to 60 000
Equipped truck mass, kg10 000
Fifth wheel load, kgup to 23 000
EngineEuro-3 (Euro-2)
Engine power, kw (h.p.)301 (410); 338 (460)
Control fuel consumption at V=60 km/hr and
gross mass of truck trailer, l/100 km31.6

*Standard
of quality!*



JSC "MAZ-MAN"
MANUFACTURING PLANT
HEAVY LOAD TRUCKS
OF WEST-EUROPEAN QUALITY

220021, Republic of Belarus, Minsk, Tsentralnaya str., 3A
Tel. (+375 17) 217-62-00; fax 217-62-01
Sales department: (+375 17) 217-62-10, 217-62-14, 217-62-15; fax 217-62-11
Service department: (+375 17) 217-62-46, 217-62-47, 217-62-19; fax 217-62-48
e-mail: sales@maz-man.com.by <http://www.maz-man.by>

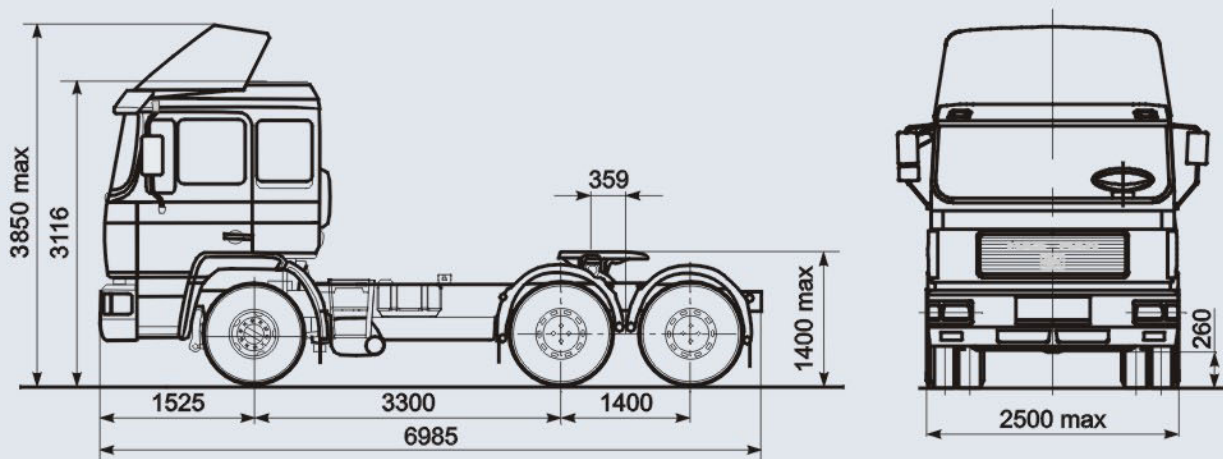

STANDARD MODIFICATION OF TRUCK TRACTOR MAZ-MAN 642268 (6X4)

Technical parameters	Gross mass of truck trailer - 53 000 kg (60 000 kg) Equipped truck mass - 10 000 kg Fifth wheel load - 15 000, 17 000, 19 000, 23 000 kg (depending on corresponding front and rear suspension)
Engine	MAN D 2866 LF 31; MAN D 2876 LF 06, MAN D 2866 LF 25, EURO-2 (EURO-3) Engine power - 301 kw (410 h.p.); 338 kw (460 h.p.) Electronic control of fuel feed (EDC) Air intake behind the cabin with dry filter element Exhaust silencer on one side with exhaust to the left Fifth wheel height 1.340 mm, 1.400 max
Gearbox	ZF, type 16 S 181, 16+2
Clutch	VALEO, one disk, dry clutch, hydraulic drive, pneumatic support
Drive	Anti-lock brake system (ABS) Anti-slipage system (ASR) Speed limiter (Tempomat)
Frame	Standard, heavy duty, cold riveted HD - Heavy Duty, SHD - Super Heavy Duty
Suspension	Front - three-leaf springs with hydraulic shock-absorbers of the dual-side action and stabilizers Rear - spring balancing with stabilizer of cross stability
Cabin external equipment	*MAN "F-2000" of high roominess, with two sleeping bunks Cathodic dip paint-work and cavity sealing *Four-point suspension on helical springs with cross stabilizer *Spoiler of the same color as cabin Sun visor over the windscreen Hydraulic cabin tilt Safety triplex windscreen laminated glass Heated, electrically regulated mirrors: back view (2), panoramic view and curb view Reinforced steel front bumper Tool boxes (40 l) on each side
Cabin internal equipment	*Two sleeping bunks Driver's seat pneumatic suspension "Isringhausen" Three-point safety belts for driver and passenger Driver's wheel with regulation of height and angle Pneumatic and electric horn Door niches, niches above windscreen and between the seats Tachograph electrical for two drivers "Kienzle" Electrical glass lifts *Outputs for radio connection 12 V, including antenna and loud-speaker *Independent air cabin heater "Eberspacher"
Brakes	Dual circuit pneumatic braking system with drum (disk) brakes Asbestos-free brake lining Brake system device "WABCO" Air-heated dehumidifier for brakes Pneumatic low noise exhaust valve brake
Electrical equipment	Alternator 28V/100A (2800 W) for Euro-3 engine or 28V/80A (2240 W) for Euro-2 engine *Battery VARTA 180 A.h Starter Bosch A001 450 321; 5.4 kw Twin halogen headlights *Two fog back-lights and two back lanterns *Additional halogen and fog lights Trailer headlights on sun visor
Fuel system	*Fuel tank 500 l (700 l) with screen filter Heated main fuel filter *Heated fuel filter water-separator "Separ-2000"
Wheels	*Tires 315/80R22.5 of West European origin *Disks 9.00"-22.5" - "Kronprinz", Germany or "Gianetti", Italy
Accessories	Standard tool kit (fire-extinguisher, first-aid kit, anti-rolling shoe, etc.) *Additional tool kit on frame
Certificates	Certificate "3" - "Euro-3 sicheres/Euro-3 safe truck" Certificate "S" - "Supergrünes und sicheres/Especially green and safe truck" (Euro-2) Certificate "L" - "Lärmarme Kraftfahrzeuge/Reduced noise" * - options are available